

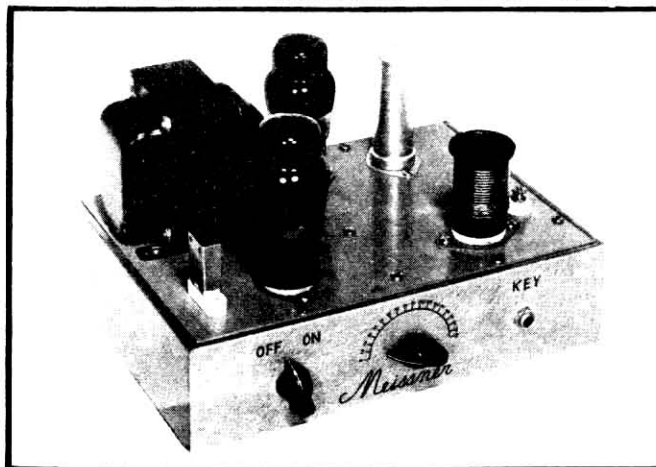

INSTRUCTIONS

For The ASSEMBLY and OPERATION

Of The MEISSNER 2-CW KIT



*This Kit available from
your Local Distributor.*

The Meissner 2-CW Transmitter Kit has been designed for both ease of assembly and simplicity of operation. Properly assembled the 14 watt (input) CW transmitter will afford many hours of operating pleasure.

The Meissner 2-CW was designed primarily for novice license operation on the 3.7-3.75 MC (coil tunes 3.5-4) band. It may also be used on the novice 26.96-27.23 MC band with proper crystal and coil. The Meissner 2-CW will operate on the 7.0-7.3, 14.0-14.4, and 21.0 to 21.45 MC bands, when used with proper crystal and coils as an AC powered transmitter or exciter. The Meissner 2-CW will operate on DC for portable or emergency use. The coil supplied with this kit is for 3.7-3.75 MC operation. Coils for other bands are available through your jobber.

Assembly of the 2-CW is made after you have read all of the instructions carefully, and studied the photographs with the parts layed out so that the entire construction can be mentally pictured. When you are able to picture each part and its place in the schematic diagram you are ready to make a step by step construction, testing as you proceed.

The first step is to mount the large components as given in the detailed instructions with the kit.

The second step is to install the small parts, wiring and testing as you proceed. All leads should be short and direct. When stripping the insulation from leads cut through the insulation about 3/8" back from the cut end being sure to scrape the wire and twist the strands tightly together. This is not necessary on the push back wire supplied as the insulation is made

to push back on the tinned wire.

The pictorial diagram shows proper small parts placement. All leads, other than insulated leads, should be kept 1/4" from the chassis. Proceed to wire and test as given in the detailed instructions with the kit.

1. Connect and solder the power transformer primary and the on-off switch.
2. Connect and solder the rectifier filament leads.
3. Wire and solder the H. V. transformer leads.
4. Test the wiring by plugging in the line cord and turning on the set. Measure voltage with an AC voltmeter from the top of the chassis.
5. Connect and wire the 6V6 filament.
6. Test to see if the 6V6 filament lights.
7. Wire the choke.
8. Connect and solder the filter condenser.
9. Mount and solder the bleeder in place.
10. Test this circuit with a D. C. voltmeter.
11. Wire the 6V6 cathode.
12. Wire the parallel fed plate of the 6V6.
13. Connect and solder the R. F. output connection checking continuity as given on the chart.
14. Mount and solder the screen bleeder and the screen by-passes. Check this circuit with an ohmmeter using the chart supplied.
15. Connect and solder the control grid circuit of the 6V6 checking as before.

OPERATION

AN AMATEUR RADIO LICENSE IS REQUIRED TO OPERATE THIS TRANSMITTER.

After the wiring has been completed and checked as given the 2-CW may be resonated.

Plug in the tubes, crystal and coil. Connect a D. C. milliammeter 0-100 ma, across the metering terminals of the terminal strip. If you do not have a meter a #40 mazda lamp will work.

Connect an eight watt bulb across the output terminals. Plug in the key jack and turn on the power.

Allow a few seconds for the tubes to warm up, and while observing the meter close the key until the meter comes to rest. Note the current reading on the meter or the brilliance of the bulb.

Rotate the variable condenser through its range and notice that the meter current dips or the bulb dims. This point is the resonance point and it is the position where the plate circuit of the oscillator is tuned to the frequency of the crystal. The correct operating point is not at absolute minimum but at a point slightly toward the side of gradual decrease of plate current as shown on the meter or bulb.

Set the variable condenser at the operating point, turn off the switch, and remove the antenna load. You are now ready to connect the antenna. Remember, a licensed operator must operate this transmitter. There are no exceptions.

The 2-CW output circuit is designed to operate into a balanced line of any length. This may be made of 300 ohm twin lead or open wire line. To determine the antenna length for a balanced line using a folded doublet antenna the equation is:

$$L = 468 / F$$

L - Required length of antenna in feet.
F - The crystal frequency in megacycles.

The 2-CW may be operated into multipliers or other tubes or link coupled to antenna tuners. However, capacity coupling is not recommended if harmonic outputs will result in undesired television interference (TVI).

With little change the 2-CW may be operated on emergency power supplies. Should the antenna load exceed 65 ma. when properly tuned the antenna coupling coil should be spread slightly, moving the bottom turn away from the large coil. Continue uncoupling the coil until the plate current falls below 65 ma.

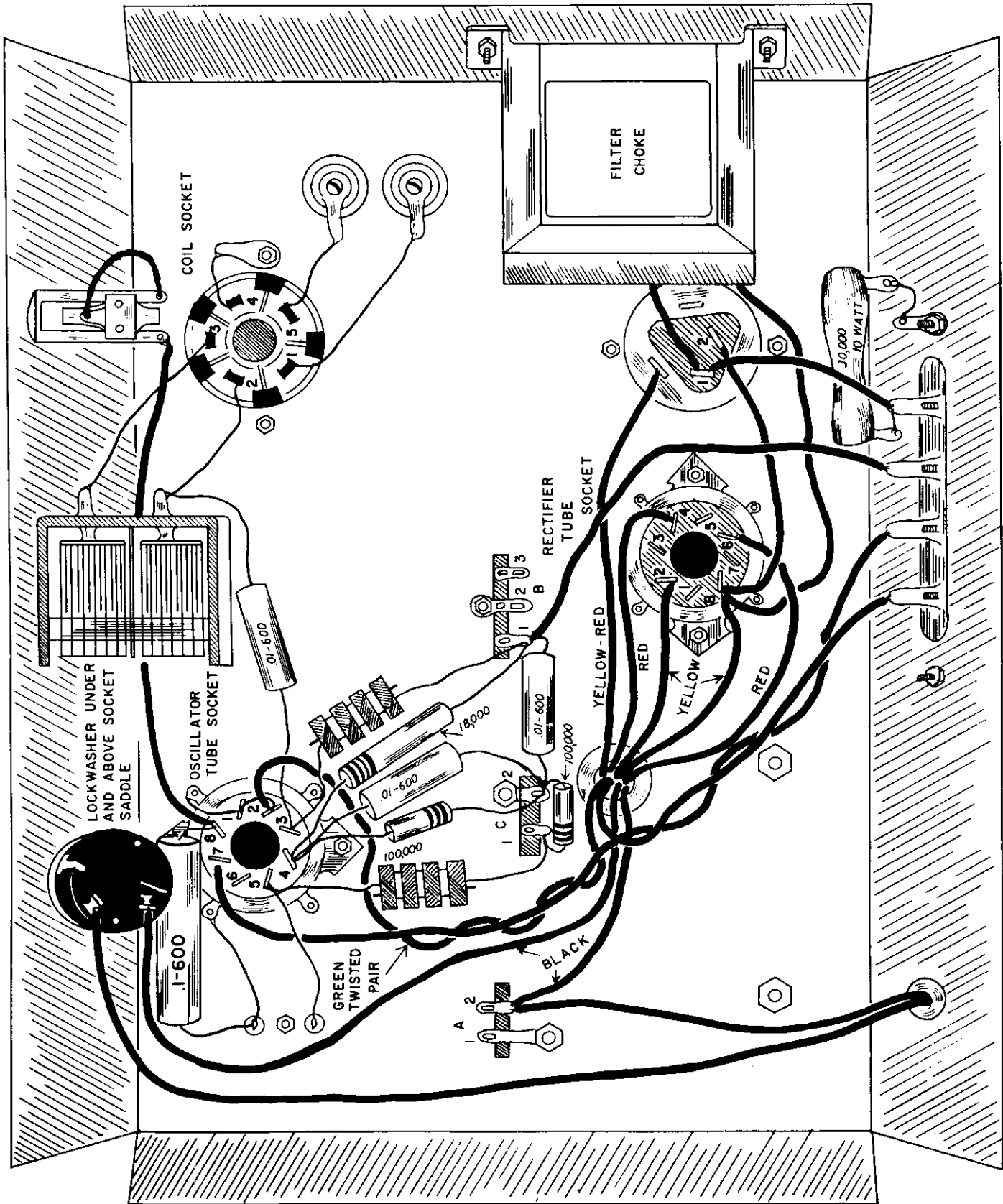

MEISSNER 2-CW
SCHEMATIC DIAGRAM

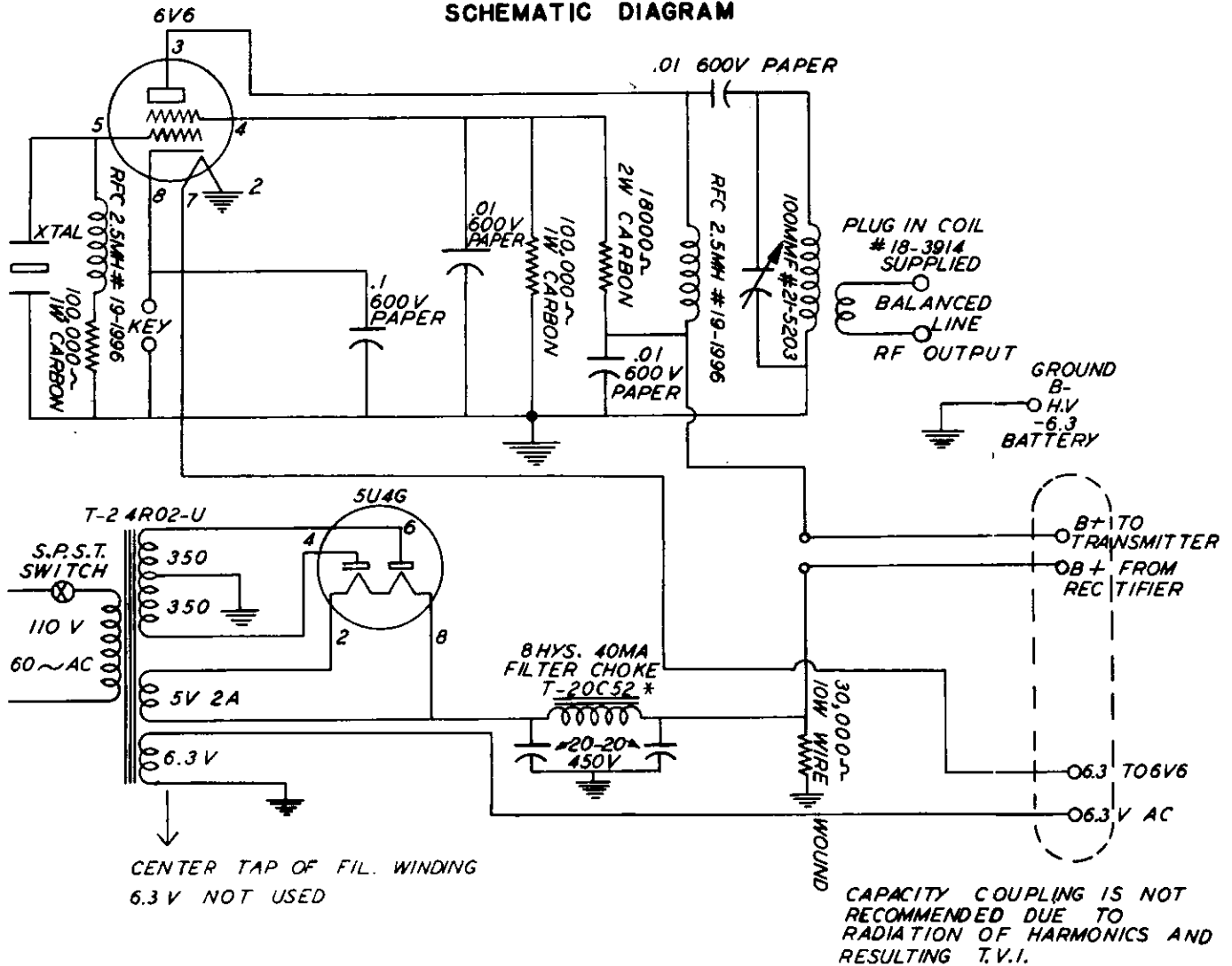

* T-20C53 MAY BE SUPPLIED

2-CW KIT PARTS LIST
DESCRIPTION

	PART NO.		PART NO.
Chassis	06401	10-32 Ext. Lockwashers	11604
Transformer	T-24R02U	1 Ins. Tie Point	06402
Choke	T-20C52 *	1 Ins. Tie Point	15787
Filter Condenser	16124	1/2" Grommet	14223
Variable Condenser	21-5203	Hardware Kit	06412
Socket 8 Prong	9309	6-32 X 3/8 RHB Screws	11212
Socket 5 Prong	29316	6-32 X 1/4 St. Cp. Hex Nut	11322
Crystal Socket	29628	#6 Ext. Lockwashers	16642
Phone Jack	19470	Mae West Lug #6	11422
Switch	19475	Cond. Mounting Plate	19286
RF Choke	19-1996	6-32 X 3/16" BH ST CP Screw	17668
Line Cord	12434	Hardware Kit	06413
Terminal Strip	21723	4-36 X 5/8 RHB CP Screw	11204
.01 600V Paper Condenser	28101	4-36 X 3/16 St. CP Nut	11336
.1 600V Paper Condenser	34158	6-32 X 1-1/8 RHB Screw	11215
100,000 Ohm 1 Watt Carbon Resistor 20%	RC30 AE 104M	6-32 X 5/16 Brass Nut	11303
18,000 Ohm 2 Watt Carbon Resistor 20%	RC40 AE 183M	Lockwasher	16639
2 Ins. Tie Point	16752	Lockwasher	11347
30K 10W Wire Wound Resistor	R-1637	3-8 Knurled Nut	21336
Knobs	23-8221	3-8 Hex Nut	21619
Ceramic Insulator Sets	27-1000	3/8 Int. Lockwasher	19470-C
Hardware Kit	06411	3/8 ID X 5/8 OD Flat Washer	18-3914
10-32 X 3-8 FHB Screws	18607	Plug in Coil	J-516
10-32 Nuts	11352	Instruction Sheet	